

HIGH EFFICIENCY DOUBLE MOVEMENT BLENDER

FX series -Heavy Duty



Patent No: ZL20162015-6
Revision date: Apr.12, 2023



FEKMASS TECHNOLOGY INC
304, Building 2, No.81 North Jingsan road,
Zhengzhou 450000, China.
Tel: +86 371 87093270
www.fekmass.com
info@fekmass.com

TWO OPTIONS FOR THE BLENDER BODY

Carbon steel body

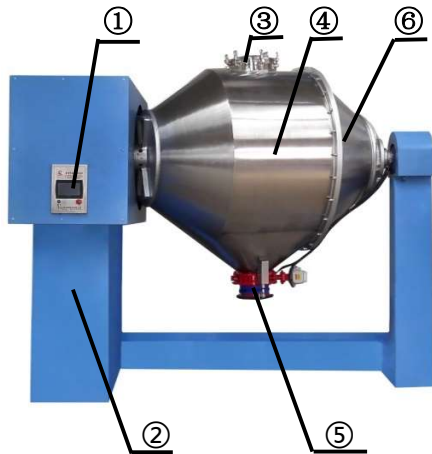

- ① Control panel
- ② Blender body
- ③ Feed inlet valve
- ④ Blender drum
- ⑤ Discharge outlet valve
- ⑥ Liquid spray system

Stainless steel body

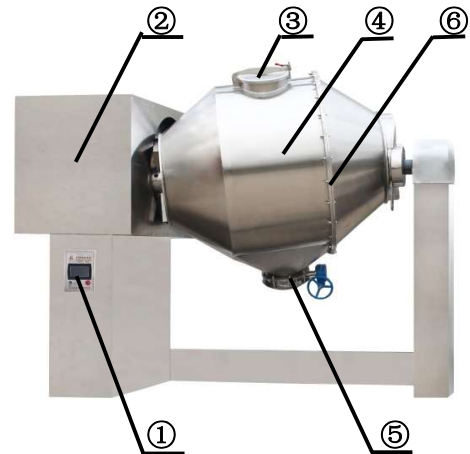

- ① Control panel
- ② Blender body
- ③ Feed inlet valve
- ④ Blender drum
- ⑤ Discharge outlet valve
- ⑥ Liquid spray system

Configuration:

Details	Standard configuration	Optional
① Control panel	Physical buttons	Touch screen
② Blender body	Carbon Steel	Stainless steel 304
③ Feed inlet valve	Hand valve	Automatic valve
④ Blender drum	Stainless steel 430	Stainless steel 304
⑤ Discharge outlet valve	Hand valve	Automatic valve
⑥ Liquid spray system	None	Available

Notes:

Accept other custom made requirements.

WHY FEKMASS BLENDER ?

Double movement mixing, increase efficiency by 70%.

With 80% loading rate, very-high mixing uniformity.

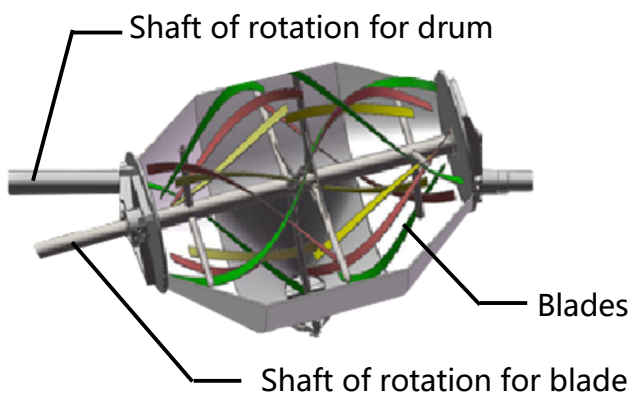

Our advantages:

- Double movement when mixing
- Special blade design
- Separate rotating for drum shaft
- Separate rotating for blade shaft

Features:

- Double movement mixing, very-high mixing uniformity
- High efficiency, save 70% mixing time
- High loading rate, 80% of the drum volume
- Meet the request of fine-scale mixing for new materials
- Does not damage the shape of the original particle
- The light powder and heavy powder are easy to mix evenly
- The trace elements are easy to mix evenly

Compared with other blenders:



V type mixer
Small volume
45% low loading rate



3-Dimensional blender
Small volume
40% low loading rate



Single cone mixer
Volum < 5000L
60% loading rate



Ribbon mixer
Bad mixing uniformity
65% loading rate



FEKMASS FX blender
Volume up to 15000L
80% loading rate

WHAT MATERIALS CAN BE MIXING ?

Application area & Materials

- Chemicals
- Battery
- Powder metallurgy
- Diamond superhard material
- New materials
- Cosmetic
- Animal feed
- Pesticide
- Fertilizer
- Dyestuff/Pigment
- Building material
- Fingernail oil
- Life science
- Biologics
- Additives
- Agricultural products
- Powder coating
- Environment



SELECT YOUR SUITABLE MODEL

Model	Drum Volume (L)	Loading Volume (L)	Loading Weight (Kgs)	Drum rotation speed (r/min)	Blade rotation speed (r/min)	Motor (Kw)	Dimension (mm)	Total weight (Kgs)
FX-1000	1000	800	1800	11	22	7.5	2550*1350*1900	2300
FX-1500	1500	1200	3000	8	16	15	2850*1870*2240	2600
FX-2000	2000	1600	4000	6	12	18.5	3200*1970*2470	2900
FX-3000	3000	2400	5000	5	12	22	3800*2100*2900	3500
FX-5000	5000	4000	6000	5.5	11	30	4500*2500*3200	4500
FX-7000	7000	5600	7000	5	10	37	4750*2650*3800	6000
FX-8000	8000	6400	8000	5	10	37	4900*2700*4000	7000
FX-10000	10000	8000	10000	3	6	45	5200*3200*4200	8600
FX-12000	12000	9600	12000	2	4	55	5600*3700*4500	9800

Notes:

Above dimensions are for reference only.
 Accept custom size and larger size.

AFTER-SALES SERVICE

Warranty service: 1 year

Strong technical team, Professional after-sales service

Help you solve any difficulties during the mixing process.



CONTACT FEKMASS

FEKMASS TECHNOLOGY INC
304, Building 2, No.81 North Jingsan road,
Zhengzhou 450000, China.
Tel: +86 371 87093270
www.fekmass.com
info@fekmass.com